



LEGAL IN CALIFORNIA ONLY FOR RACING VEHICLES WHICH MAY NEVER BE USED, REGISTERED OR LICENSED FOR USE UPON A HIGHWAY.

See knfilters.com for CARB status on each part for a specific vehicle

INSTALLATION INSTRUCTIONS

77-1513KP

JEEP

1999-04 Grand Cherokee

V8-4.7L

NOTE: This kit was not designed to fit vehicles with a body lift.

TOOLS NEEDED:

Flat blade screwdriver
Ratchet
Extension
10mm socket
13mm socket
15mm socket
17mm socket
10mm end wrench
13mm end wrench
15mm end wrench

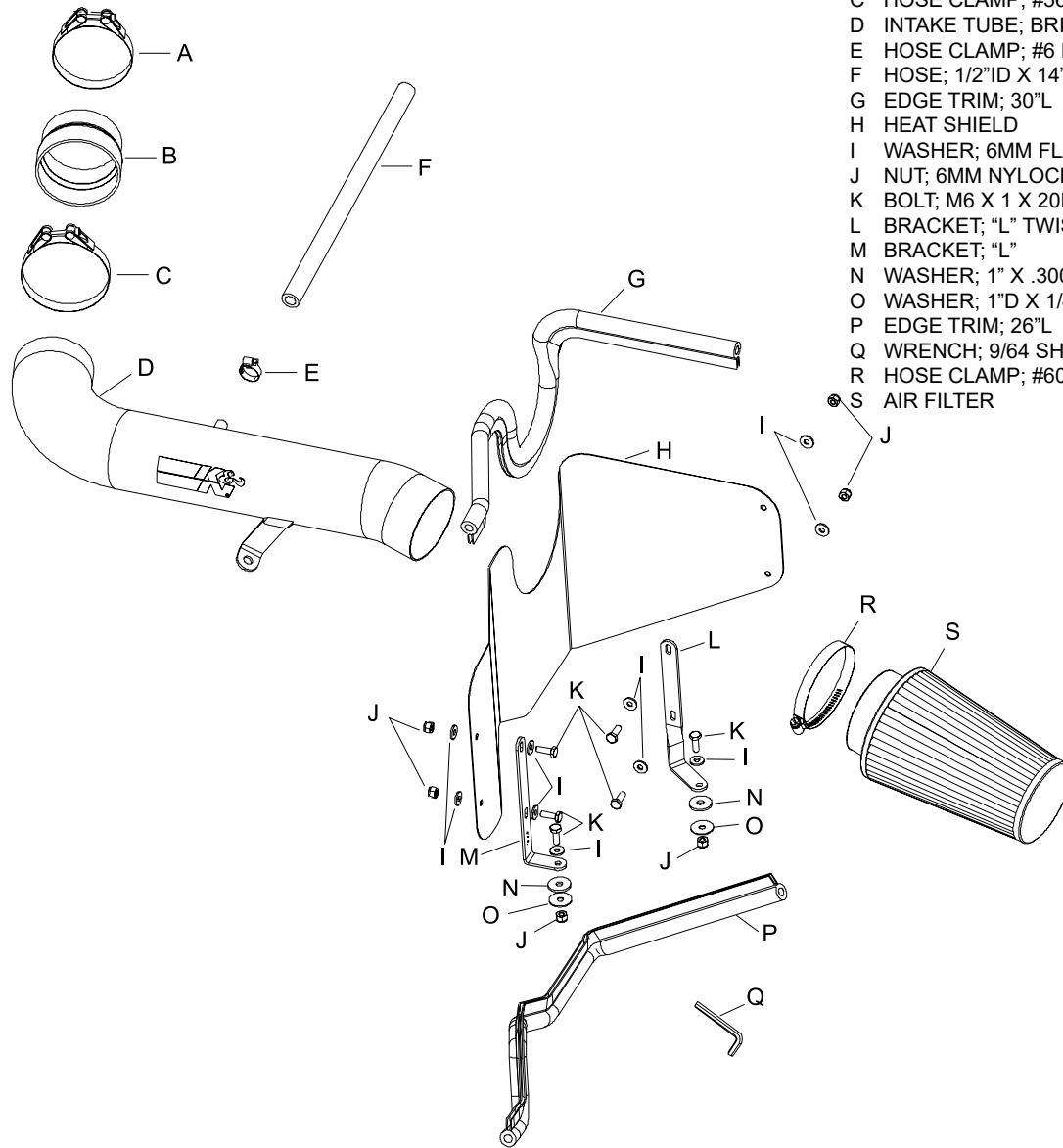

PARTS LIST:

Description	Qty.	Part #
A HOSE CLAMP; #52	1	08610
B HOSE; 3.25"ID TO 3.5"ID	1	084091
C HOSE CLAMP; #56	1	08620
D INTAKE TUBE; BRIGHT	1	27422AKP
E HOSE CLAMP; #6 MINI	1	08407
F HOSE; 1/2"ID X 14"L	1	08402
G EDGE TRIM; 30"L	1	102489A
H HEAT SHIELD	1	07423
I WASHER; 6MM FLAT	10	08269
J NUT; 6MM NYLOCK	6	07512
K BOLT; M6 X 1 X 20MM	6	07795
L BRACKET; "L" TWIST	1	070912
M BRACKET; "L"	1	070902A
N WASHER; 1" X .300 X .063	2	21685
O WASHER; 1"D X 1/4" HOLE	2	08160
P EDGE TRIM; 26"L	1	102488
Q WRENCH; 9/64 SHORT	1	69802
R HOSE CLAMP; #60	1	08624
S AIR FILTER	1	RU-1045

If you need any assistance please call 1-800-858-3333 to speak with a representative in our Customer Service Center before returning the product.

NOTE: FAILURE TO FOLLOW INSTALLATION INSTRUCTIONS AND NOT USING THE PROVIDED HARDWARE MAY DAMAGE THE INTAKE TUBE, THROTTLE BODY AND ENGINE.

TO START:

1. Turn off the ignition and disconnect the negative battery cable.
NOTE: Disconnecting the negative battery cable erases pre-programmed electronic memories. Write down all memory settings before disconnecting the negative battery cable. Some radios will require an anti-theft code to be entered after the battery is reconnected. The anti-theft code is typically supplied with your owner's manual. In the event your vehicles anti-theft code cannot be recovered, contact an authorized dealership to obtain your vehicles anti-theft code.



2. Detach the crankcase vent hose from the stock intake tube.



3. Loosen the hose clamp on the intake hose at the intake tube.



4. Release the 4 over center clips that retain the airbox top to airbox base.

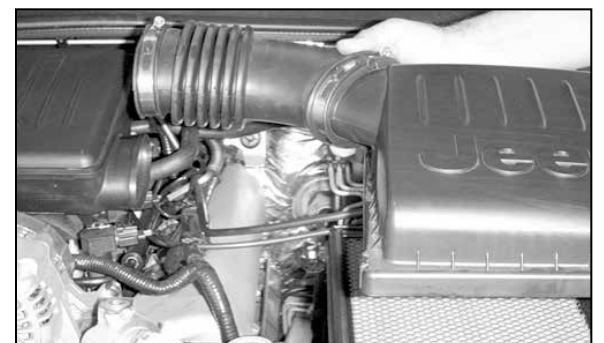

5. Detach the intake hose from the intake tube and remove the entire upper airbox assembly.



6. Loosen the hose clamp on the intake tube at the throttle body.



7. Loosen and remove the 2 bolts that retain the intake tube to the intake manifold.

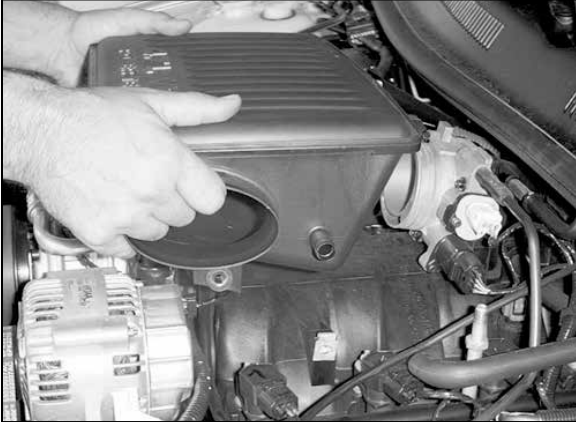

8. Pull firmly upward and remove the intake tube assembly.

NOTE: K&N Engineering, Inc., recommends that customers do not discard factory air intake.



9. Detach the OE crankcase vent hose from the "T" fitting.

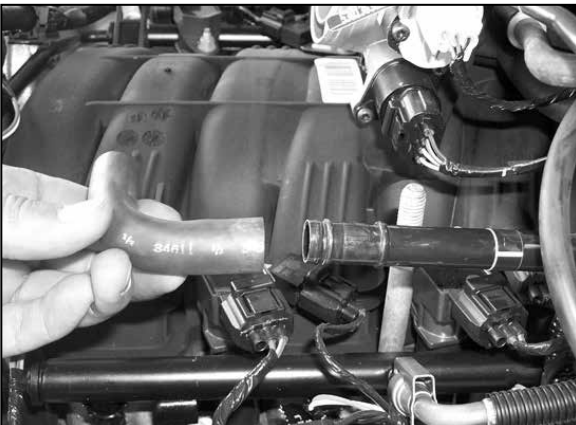

9a. On 2003 models, detach the 90 degree hose from crankcase vent as shown.

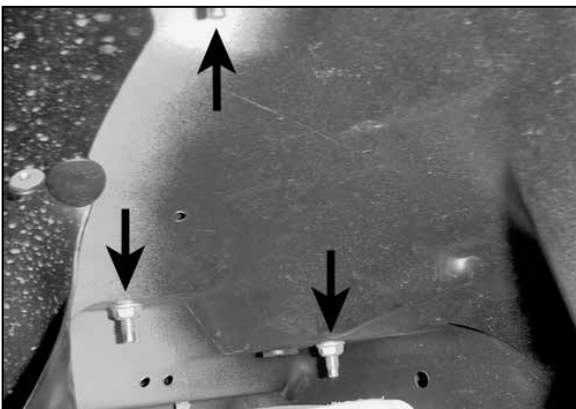

10. Loosen and remove the 3 nuts that retain the airbox base to the inner fender apron.

NOTE: These are accessed from the underside of the fender.



11. Detach the air inlet duct from the air box base and remove the air box base.



12. Release the clip that retains the air inlet duct to the radiator core support and remove the air inlet duct.

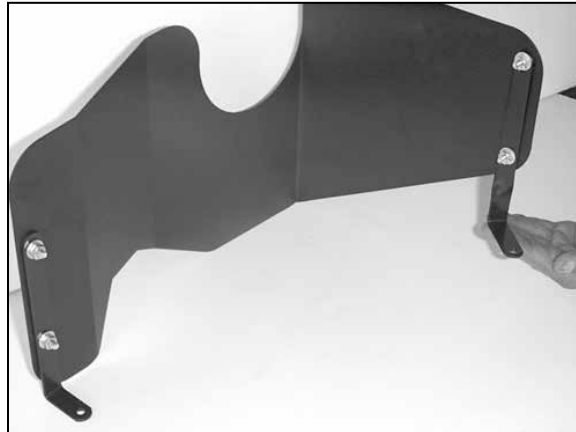

13. Attach the "L" bracket and the twisted "L" bracket to the heat shield using the hardware provided.



14. Install the trim seal onto the heat shield as shown.

NOTE: Some trimming of the edge trim will be necessary.

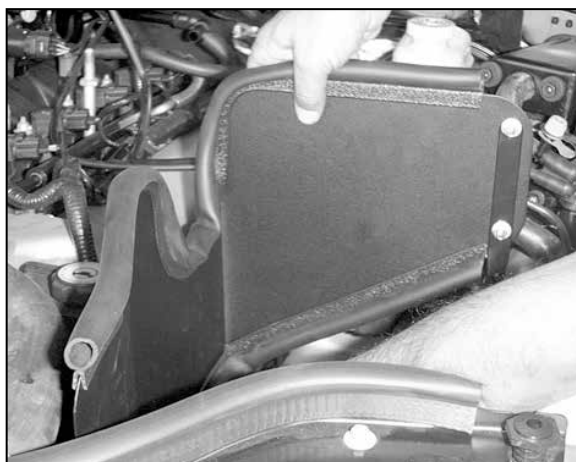

15. Install the heat shield assembly.

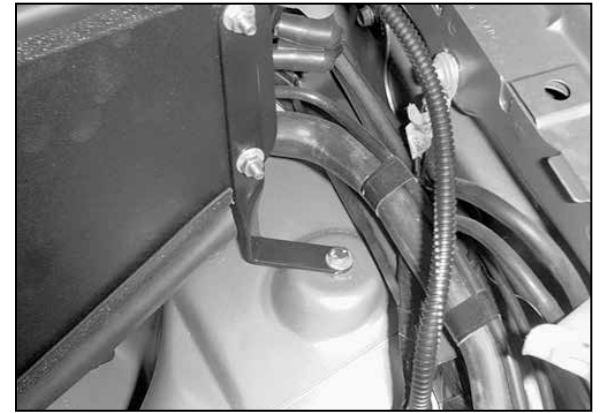

16. Attach the "L" twist bracket to the existing airbox mounting point on the inner fender apron using the hardware provided.

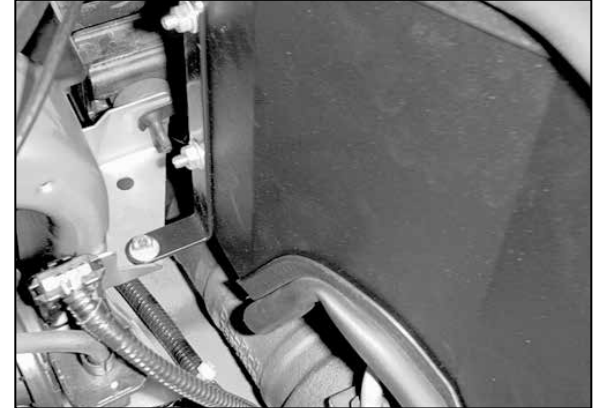

17. Attach the "L" bracket to the radiator mounting bracket using the hardware provided.

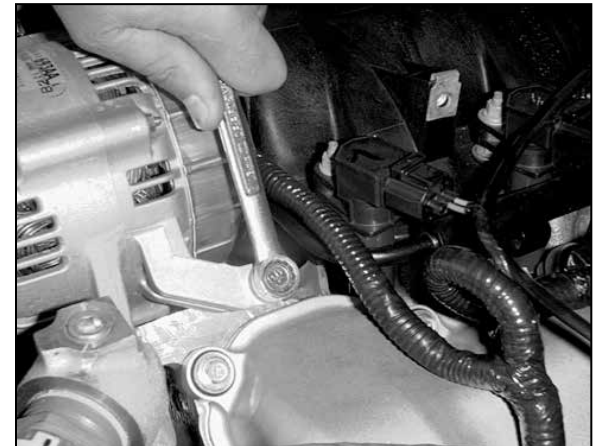

18. Loosen and remove the alternator retaining bolt.



19. Install the provided silicone step hose and hose clamps onto the throttle body as shown.



20. Slide the K&N® intake tube into the silicone hose on the throttle body and secure the bracket to the alternator using the stock bolt removed in step 18.

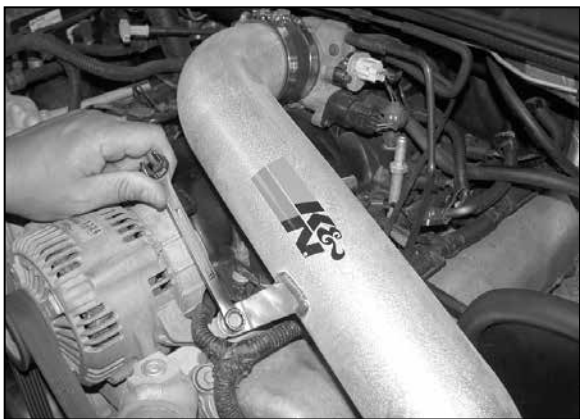

21. Adjust everything for best fit and clearance then tighten the alternator bolt as shown.



22. Attach the vent hose provided to the "T" fitting.



23. Connect the other end of the silicone hose to the vent on the K&N® intake tube as shown.

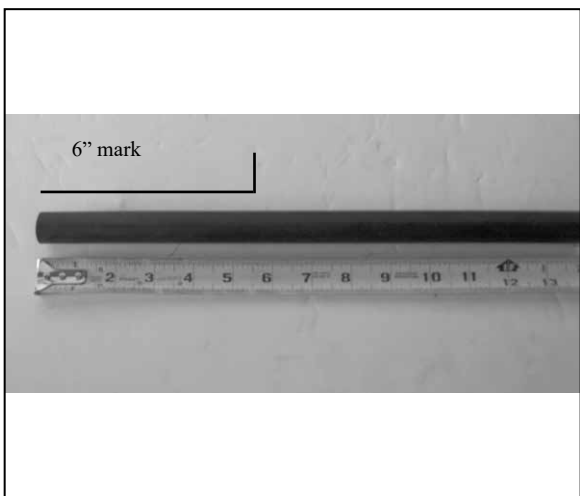

24. On 2003 models, cut 6 inches of the provided silicone hose as shown.



25. On 2003 models slide the silicone hose from step 24 onto the crank case vent hard line as shown.



26. On 2003 models connect the crank case vent hose to the K&N® intake as shown.



27. Install the K&N® air filter on the K&N® intake tube and secure with the provided hose clamp as shown.

NOTE: Drycharger® air filter wrap; part # RF-1045DK is available to purchase separately. To learn more about Drycharger® filter wraps or look up color availability please visit <http://www.knfilters.com>.



28. Reconnect the vehicle's negative battery cable. Double check to make sure everything is tight and properly positioned before starting the vehicle.

29. Reconnect the vehicle's negative battery cable. Double check to make sure everything is tight and properly positioned before starting the vehicle.

30. It will be necessary for all K&N® high flow intake systems to be checked periodically for realignment, clearance and tightening of all connections. Failure to follow the above instructions or proper maintenance may void warranty.

ROAD TESTING:

1. Start the engine with the transmission in neutral or park, and the parking brake engaged. Listen for air leaks or odd noises. For air leaks secure hoses and connections. For odd noises, find cause and repair before proceeding. This kit will function identically to the factory system except for being louder and much more responsive.

2. Test drive the vehicle. Listen for odd noises or rattles and fix as necessary.

3. If road test is fine, you can now enjoy the added power and performance from your kit.

4. K&N Engineering, Inc., requires cleaning the intake system's air filter element every 100,000 miles. When used in dusty or off-road environments, our filters will require cleaning more often. We recommend that you visually inspect your filter once every 25,000 miles to determine if the screen is still visible. When the screen is no longer visible some place on the filter element, it is time to clean it. To clean and re-oil, purchase our filter Recharger® service kit, part number 99-5050 or 99-5000 and follow the easy instructions.

LEGAL IN CALIFORNIA ONLY FOR RACING VEHICLES WHICH MAY NEVER BE USED, REGISTERED OR LICENSED FOR USE UPON A HIGHWAY.

See knfilters.com for CARB status on each part for a specific vehicle